



550-100 Non-EMI D-Subminiature Split Backshell

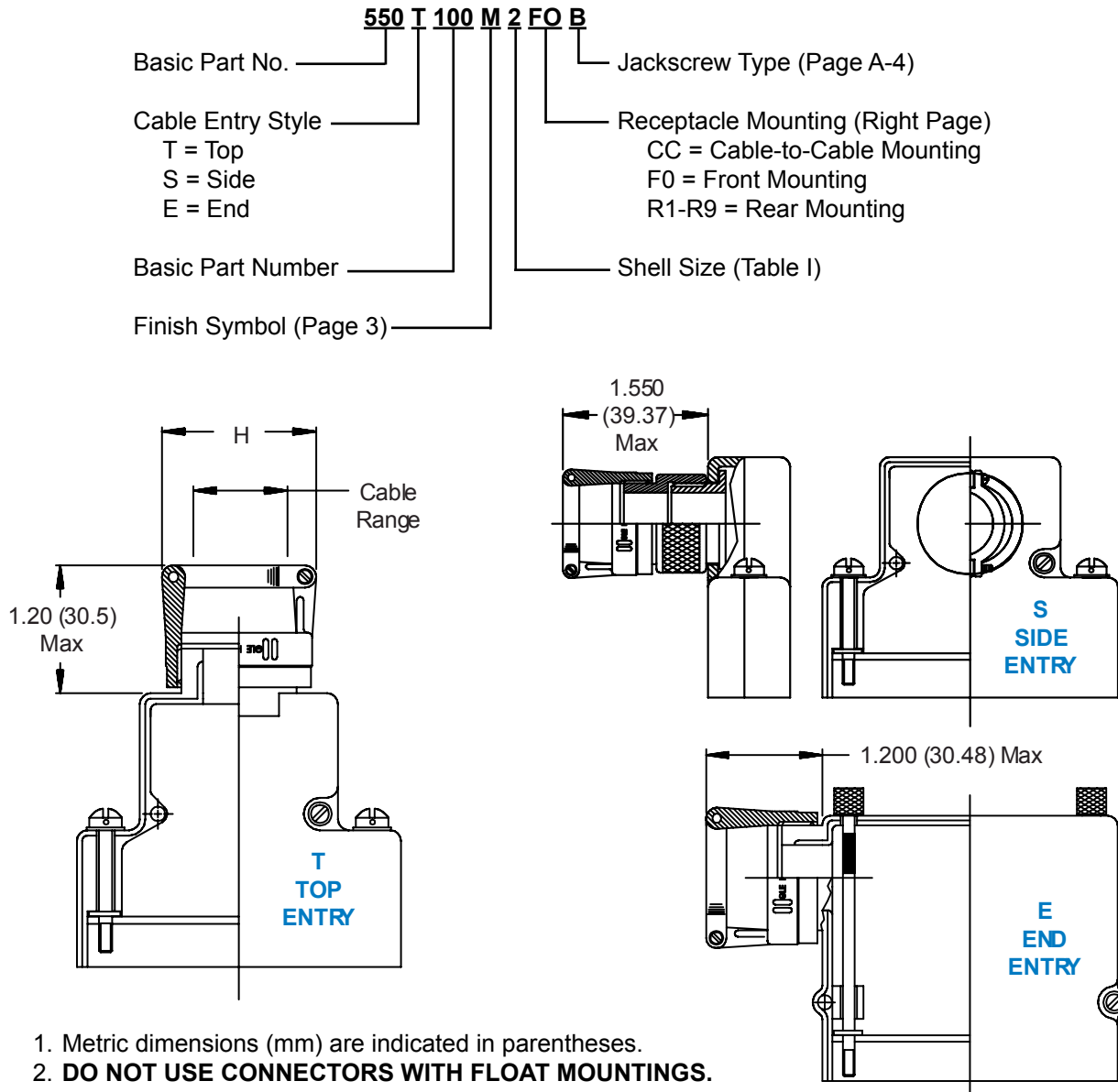
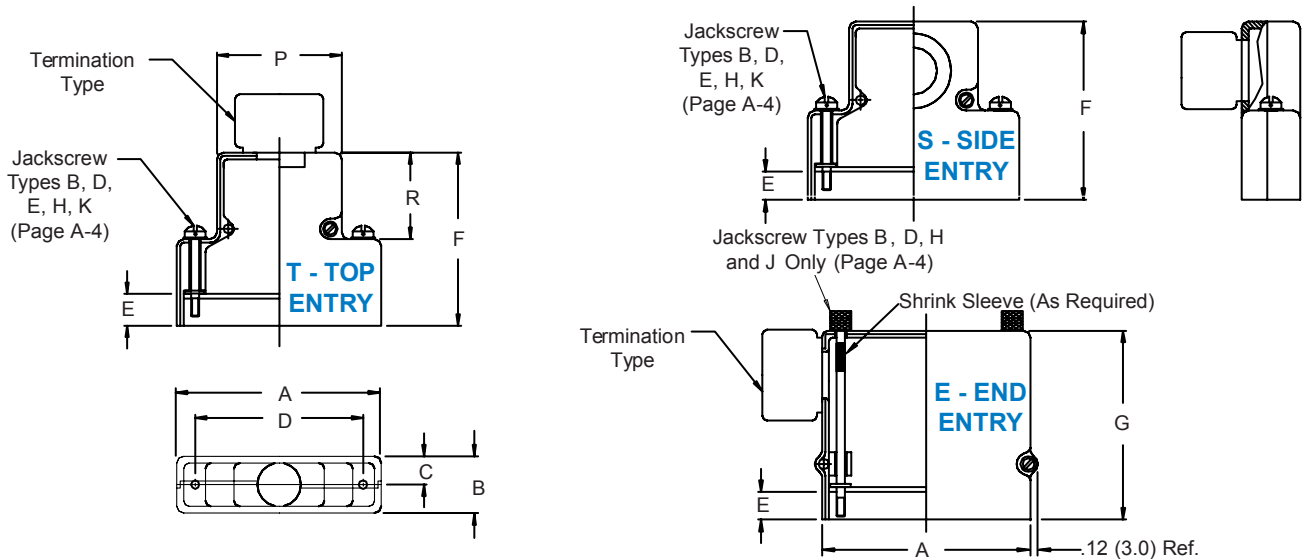

TABLE I: SHELL SIZE, CABLE ENTRY & STYLE

Shell Size	Com'l Shell Size Ref	H Max	Entry Styles S & T Cable Range		Entry Style E Cable Range	
			Min	Max	Min	Max
1	E/09	1.046 (26.6)	.125 (3.2)	.250 (6.4)	.250 (6.4)	.375 (9.5)
2	A/15	1.046 (26.6)	.250 (6.4)	.375 (9.5)	.250 (6.4)	.375 (9.5)
3	B/25	1.156 (29.4)	.312 (7.9)	.475 (12.1)	.312 (7.9)	.475 (12.1)
4	C/37	1.156 (29.4)	.312 (7.9)	.475 (12.1)	.312 (7.9)	.475 (12.1)
5	D/50	1.218 (30.9)	.437 (11.1)	.575 (14.6)	.437 (11.1)	.575 (14.6)
6*	F/104	1.594 (40.5)	.812 (20.6)	1.000 (25.4)	n/a	n/a

* Shell Size 6 Available in Top Entry Only.

D-Subminiature Split Backshells Standard Dimensions



COMMON CONNECTOR/SHELL INTERFACE & BACKSHELL DIMENSIONS

Shell Size	Com'l Shell Ref	A		B		C Ref.		D		P	R Ref		
		Max	(mm)	Max	(mm)		(mm)	$\pm .005$	(.1)				
1	E/09	1.393	(35.4)	.624	(15.8)	.312	(7.9)	.984	(25.0)	.730	(18.5)	.719	(18.3)
2	A/15	1.706	(43.3)	.624	(15.8)	.312	(7.9)	1.312	(33.3)	1.050	(26.7)	.719	(18.3)
3	B/25	2.265	(57.5)	.624	(15.8)	.312	(7.9)	1.852	(47.0)	1.594	(40.5)	.938	(23.8)
4	C/37	2.900	(73.7)	.624	(15.8)	.312	(7.9)	2.500	(63.5)	2.240	(56.9)	.938	(23.8)
5	D/50	2.800	(71.1)	.750	(19.1)	.375	(9.5)	2.406	(61.1)	2.140	(54.4)	.938	(23.8)
6	F/104	2.900	(73.7)	.844	(21.4)	.422	(10.7)	2.500	(63.5)	2.240	(56.9)	1.094	(27.8)

CABLE MOUNTING AND BACKSHELL DIMENSIONS

Dash No.	Panel Thickness	E	F $\pm .031$ (0.79)			G $\pm .031$ (0.79)	
			Sizes 1 & 2	Sizes 3 - 5	Size 6	Sizes 1 & 2	Sizes 3 - 5
CC	n/a	.174 (4.4)	1.451 (36.9)	1.671 (42.4)	1.820 (46.2)	1.583 (40.2)	1.831 (46.5)
F0	n/a	.343 (8.7)	1.625 (41.3)	1.844 (46.8)	2.000 (50.8)	1.750 (44.5)	2.000 (50.8)
R1	.031 (.8)	.247 (6.3)	1.525 (38.7)	1.745 (44.3)	1.890 (48.0)	1.656 (42.1)	1.904 (48.4)
R2	.047 (1.2)	.231 (5.9)	1.509 (38.3)	1.728 (43.9)	1.875 (47.6)	1.640 (41.7)	1.888 (48.0)
R3	.062 (1.6)	.216 (5.5)	1.500 (38.1)	1.720 (43.7)	1.860 (47.2)	1.625 (41.3)	1.873 (47.6)
R4	.093 (2.4)	.185 (4.7)	1.470 (37.3)	1.690 (42.9)	1.829 (46.5)	1.594 (40.5)	1.842 (46.8)
R5	.104 (2.6)	.174 (4.4)	1.451 (36.9)	1.671 (42.4)	1.820 (46.2)	1.583 (40.2)	1.831 (46.5)
R6	.125 (3.2)	.153 (3.9)	1.430 (36.3)	1.650 (41.9)	1.798 (45.7)	1.563 (39.7)	1.811 (46.0)
R7	.156 (4.0)	.125 (3.2)	1.400 (35.6)	1.620 (41.1)	1.767 (44.9)	1.531 (38.9)	1.781 (45.2)
R8	.135 (3.4)	.140 (3.6)	1.417 (36.0)	1.637 (41.6)	1.805 (45.8)	1.550 (39.4)	1.798 (45.7)
R9	.188 (4.8)	.094 (2.4)	1.368 (34.7)	1.590 (40.4)	1.740 (44.2)	1.500 (38.1)	1.750 (44.5)

Metric dimensions (mm) are indicated in parentheses.